

# AEA N22

## OWNER'S MANUAL



ACTIVE NEAR-FIELD RIBBON MIC

---

# WELCOME

Congratulations on your purchase of the AEA N22 phantom-powered ribbon microphone and welcome to the AEA family. Hard working artists, honing their musical craft for many years, feel strongly about their personal tone, so they need a microphone that translates their signature sound in a recording. Whether you are a musician, home studio owner, or experienced producer/engineer, you will find that the N22 provides a great ribbon tone without the need for EQ in most applications. Most importantly, the N22 was designed by listening first, and measuring only after experienced musicians told us the microphone sounded great. Bridging the gap between vintage and modern, studio and live, the N22 is the perfect companion for musicians and engineers alike.

Your N22 microphone is 100% handcrafted in Pasadena, CA. AEA is a family owned company with a small crew of skilled technicians - most of them being musicians themselves. Proudly independent, we still manufacture all our ribbon microphones and preamps by hand from locally sourced parts.

We hope that the N22 will help you capture many magical performances that touch the heart. Read this manual thoroughly to make sure that you get the best sound and longevity from your new microphone. Please don't be a stranger and become part of the AEA community by sharing your experiences with the N22 via e-mail, phone or our social media channels.

*Wes Dooley*  
*President of AEA*

# CONTENTS

<b>2</b>	<b>WELCOME</b>
<b>4</b>	<b>INTRODUCTION</b>
<b>4</b>	<b>SUPPORT</b>
<b>5</b>	<b>GENERAL GUIDELINES</b>
<b>7</b>	<b>APPLICATION ADVICE</b>
<b>11</b>	<b>SPECIFICATIONS</b>

# INTRODUCTION

The N22 is a side-address, phantom-powered ribbon microphone with a bidirectional (or figure-of-8) pickup pattern. It was designed for close-up miking applications like acoustic and electric guitars, vocals, drums, or piano, but it is also well suited to be used at a distance thanks to its healthy output level. With phantom-powered JFET electronics and a custom German transformer the N22 achieves optimal performance with a wide range of preamps ranging from vintage high-end models to USB or Firewire audio interfaces in home studio setups. The highly protected pure aluminum ribbon allows for using the N22 in live sound applications and vocal recording without the need for an additional pop-filter. The N22 is the first member of AEA's NUVO series. Rooted in the RCA tradition just like other AEA ribbons, all NUVO microphones are designed to offer a fresh approach to the ribbon transducer and represent Wes Dooley's take on the evolution of the ribbon microphone.

## WARRANTY

Your N22 mic comes with a one-year limited warranty on parts and labor, shipping not included. **Registering your product with AEA will extend the warranty to a full three years.**

Register your microphone at [AEAribbonmics.com/register-your-aea](https://www.aearibbonmics.com/register-your-aea).

## SUPPORT

If you should encounter any problems with your microphone or have questions regarding using your N22 mic in specific application, please contact our customer support team at [support@ribbonmics.com](mailto:support@ribbonmics.com).

To talk to a live human being, call +1 (800) 798-9127, between 9:00 A.M.- 5:00 P.M. PT Monday through Friday. AEA's repair center is located at 1029 N. Allen Ave, Pasadena, CA 91104, U.S.A.

# GENERAL GUIDELINES

Your microphone is a valuable and important investment. Like any piece of recording equipment or musical instrument, it requires common sense and good basic care to keep it working properly. Given simple, basic care, your new microphone will perform admirably for decades.

## PHANTOM POWER

Although the N22 needs a standard 48V phantom-power source to operate, you should still make sure that phantom power is turned off before plugging and unplugging the microphones. The loud pops that occur when the microphone is plugged in with phantom power engaged can damage speakers, headphones, and ears. Since passive ribbon microphones or other transformer-coupled microphones are particularly sensitive to phantom power, it is recommended always to disengage phantom power before plugging and unplugging any ribbon microphones.

The phantom current draw for active AEA ribbon mics is 7 milliamps. IEC specifies P48 power should be able to deliver 10 milliamps per input. Some USB and battery-powered audio interfaces won't deliver this. Please check the current values available on your unit to ensure the best performance.

## MICROPHONE STORAGE

**Keep the microphone covered when it is not in use.** Keeping the microphone covered when it is not in use will reduce the possibility of damage that might result from a sudden gust of air coming from air-conditioning or an open door or window. Place the supplied protective bag over the microphone when it is not in use. For long term storage, place the microphone in its protective case. Minute iron particles, sometimes known as "tramp iron," are common within our environment. AEA ribbon microphones contain powerful magnets that produce strong magnetic fields. These fields can attract any ferric metal near the microphone that, if they are small enough, can penetrate the outer screening and work their way inside the microphone. Over time, this "tramp iron" can build up sufficiently in the magnetic gap to rub against the ribbon causing

distortion, electrical shorts or tearing of the ribbon. The best prevention is to keep the microphone in its case or covered with the supplied plastic bag when it is not in use.

## AIR TURBULENCE

**Never expose the microphone to strong air turbulence.** Ribbon microphones can withstand very high SPL (Sound Pressure Level) without difficulty, but can be damaged easily by a sudden, strong gust of air or high levels of very low frequency sound waves (like from a kick drum or bass cabinet). This can stretch the ribbon, causing the microphone to start sounding flabby. Sources that may produce strong blast of air, such as the bass port on an electric guitar or bass amp, a guitar being plugged (or unplugged) while the amp level is turned fully up, an on-axis kick-drum hole (particularly with a port on the head), are potentially damaging.

To avoid possible damage, follow this simple procedure when positioning the microphone called "The Hand Test": put the back of your hand where the mic will be; if you can feel the motion of air on your hand, place a pop-filter between the microphone and the source of the wind gusts or simply pull the mic further back. When recording kick drums or bass guitar cabinets, angle the microphone to make sure that no wind blasts hit the microphone directly on-axis from the front or back.

Never blow directly into any microphone to test it. Not only does this force moisture and dirt into the microphone, strong air movement also can stretch the ribbon and while it may not break, it nonetheless could significantly degrade the microphone's performance. The ribbon in the N22 is protected by multi-layered screens and grille cloths to provide superior wind protection. Nonetheless, using it outdoors requires special care to avoid wind which can damage the ribbon. Indoors, however, it is also important to avoid serious air movement from stage curtains, open windows, doors, or air-conditioning systems.

Windtech developed a custom foam windscreen that contours the form of the N8 and N22 grille structure. This AEA NUVO windscreen provides excellent protection from wind blasts, significantly reduces breath noise on close-up vocals, and allows you to use your NUVOs outdoors. The NUVO Windscreen and other accessories can be ordered through AEA's online store.

## MAGNETIC STRAY FIELDS

Ribbon microphones are fundamentally prone to picking up strong external magnetic fields caused by light dimmers or nearby power transformers. Guitar players will know this phenomenon from single-coil pickups. Even though much attention was paid to suppressing such sensitivity to external magnetic fields in the design of your microphone, it is still possible that you might encounter this problem. If you should pick up a hum, try rotating or moving the microphone to find a spot where the hum disappears, and try eliminating potential sources of stray magnetic fields. You can use the microphone to find where hum is originating. Rotate the mic for maximum interference and move it back and forth to sense its direction.

The high-performance magnets used in AEA microphones are incredibly strong, and a significant amount of stray magnetic field lines surround the microphone. Avoid placing the microphone in close proximity to hard drives, credit cards, analog tape, or any other magnetically sensitive items to prevent any data loss.

## MICROPHONE POSITIONING

The shock-mounted clip that is supplied with the N22 microphone was designed to keep structure-borne noise transmitted through the microphone stand away from the low-tuned ribbon transducer. For the shock mount to function as intended and to avoid vibration entering the microphone through its attached cable, it is important to provide a slack loop by tying the microphone cable tightly to the microphone stand with a cable tie, shoelace, or string. (A Velcro® tie will not be tight enough.)

# APPLICATIONS ADVICE

We actively encourage users to visit [AEAribbonmics.com](https://www.aearibbonmics.com) to access our comprehensive collection of in-depth articles and tutorials featuring the N22 microphone, along with a library of audio and video demonstrations of the N22 in action.

## A FIGURE-OF-8 MICROPHONE

Figure-of-8 microphones are constructed with positive polarity on the front and negative polarity on the back. Positive pressure on the front side of the ribbon produces a positive voltage on Pin-2, with respect to Pin-3 on the output connector.

In addition to polarity, this is the result of using two wraps of grille cloth on the back and only one on the front.

When using the rear lobe, remember to invert the polarity on your preamp or DAW. This ensures your recordings with the back lobe will be in-phase with other microphones.

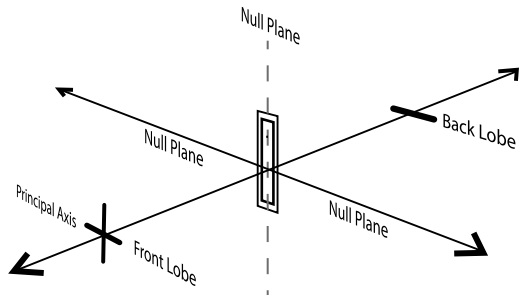

## HOW TO MINIMIZE BLEED

A significant and ever-present challenge in contemporary studio recording is minimizing “bleed” (also called “leakage” or “crosstalk”) from nearby instruments into the various microphones. The deep nulls of bidirectional ribbon microphones provide good rejection of unwanted sounds, which also can be beneficial in sound reinforcement situations where feedback is always a threat. While gobos can be effective in isolating performers from each other, they introduce their own set of problems - not the least of which are reflections in close proximity to the performers and/or microphones that result in comb-filter distortions. Since gobos usually are bulky, they also inhibit the ability of the musicians to hear and see each other easily. Such a setup requires complex and often cumbersome headphone monitor mixes for the musicians.

Since the N22 is bidirectional, it exhibits nulls at right angles to the principal axis. These nulls produce a “plane of rejection” around the sides, top and bottom of the mic that can be used effectively to reduce leakage. Simply arrange the musicians so that nearby instruments are placed in the “null” of their neighbor’s microphone, and vice versa. Although this does not entirely eliminate the need for gobos, it can significantly reduce their number.

Keep in mind that a certain degree of bleed is not necessarily bad.



For some styles and genres, it can, in fact, be beneficial to embrace a little bit of bleed in order to create cohesive and natural sounding recordings. The important thing to listen for is whether or not other instruments that bleed into a specific instrument microphone still sound natural. You will generally find that well-designed ribbon microphones like the N22 capture a natural off-axis sound, which means that bleed from other instruments can contribute to the overall sound in a pleasing way.

## PROXIMITY EFFECT

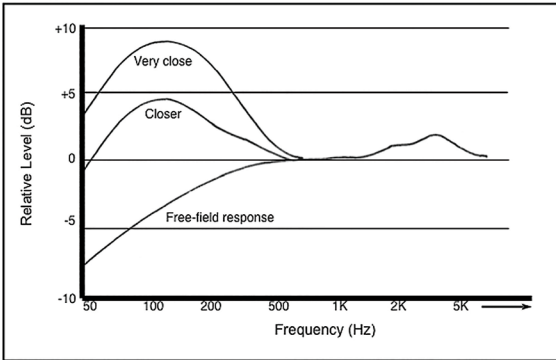

Proximity effect is a characteristic of all directional microphones; it is a rise in low-frequency response that increases at closer working distances. While this can be used to good effect, particularly with male voices to give them

an enhanced richness and depth, the potential trade-off is reduced articulation or clarity that can result from the masking effect on the treble due to “excessive” bass boost.

The N22's internal design creates a balanced treble and bass ratio at a close distance to the source. The near-field N22 contains a built-in mechanical high-pass filter that allows users to place the mic right up against an instrument. This is all done without an EQ circuit. It naturally reduces proximity effect while also avoiding the room tone that can cause problems in smaller spaces or iso booths.

## A NEAR-FIELD RIBBON

The N22 is a near-field ribbon mic and is best used up-close to the source. Its optimal distance for miking is between one and 18 inches (2 cm - 0.5 meters) and is perfect for electric guitar and bass cabs, kick drum, acoustic guitar, and vocals. Because the midrange and top-end are not obscured by proximity effect, it also alleviates the need to blend an additional dynamic mic to add more bite. Because it has less proximity effect, it allows you to get right up against the source while still retaining a balanced sound.

# SPECIFICATIONS

Operating Principle:	Pressure gradient transducer
Directional Pattern:	Bidirectional
Frequency Range:	<20 Hz to >20 kHz
Maximum SPL:	141 dB SPL (1% third harmonic > 1 kHz)
Sensitivity:	8.3 mV/Pa (at 1 kHz, no load)
Output Impedance:	92 $\Omega$ broadband
Recommended Load Impedance:	1.0 k $\Omega$ or greater
Phantom Power:	P48 phantom power, 7 mA
Polarity:	Pin 2 high for positive pressure at the front of the microphone.
Polar Response:	Native bidirectional, figure-of-8 pattern
Horizontal:	Up to 90 dB rejection at right angles to the front/back axis.
Vertical:	Level changes with angle of incidence, but frequency response is consistent.
Transducer Element Material:	Pure aluminum corrugated ribbon
Thickness:	1.8 $\mu$ m
Width:	0.185 in (4.7 mm)
Length:	2.35 in (59.7 mm)
Microphone Dimensions:	
Height:	8.83 in (22.5 cm)
Width:	1.62 in (11.7 cm)
Depth:	1.62 in (9.5 cm)
Weight:	12 oz (335 g)
Shipping Weight:	1 lb 13 oz (810 g)
Connector:	XLR-3M

## Accessories Included:

Storage/shipping case, microphone stand clip, custom protective mic sleeve, user manual.

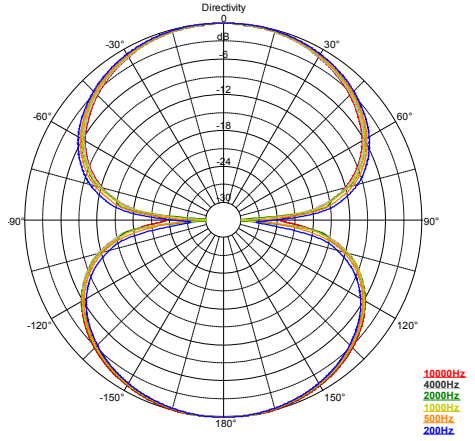
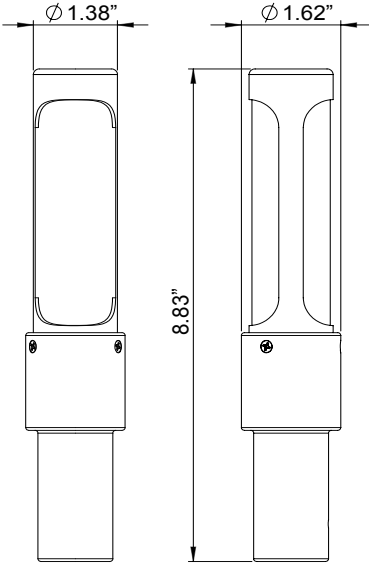

## FREQUENCY RESPONSE

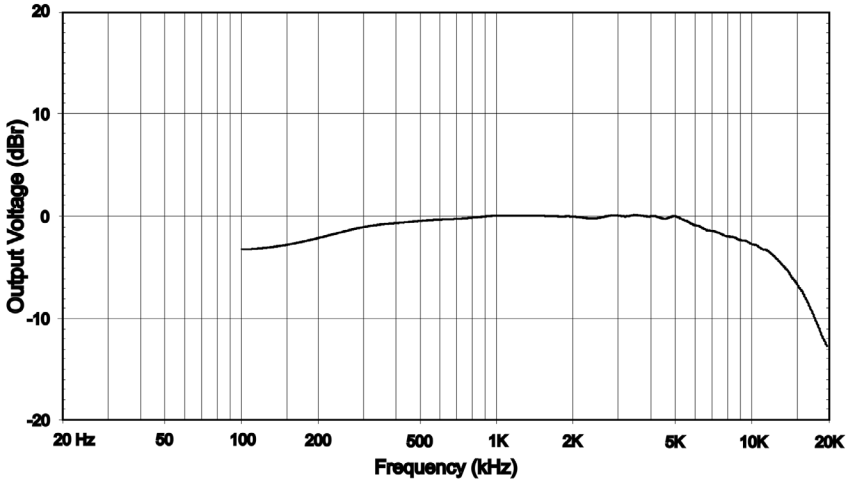

0 dB = -55dBV referenced to one Pascal (94 dV SPL).



[AEARIBBONMICS.COM](http://AEARIBBONMICS.COM) | [@RIBBONMICS](https://twitter.com/RIBBONMICS) | [INFO@RIBBONMICS.COM](mailto:INFO@RIBBONMICS.COM) | (800) 798-9127